

# International Journal of Engineering Sciences & Research Technology

(A Peer Reviewed Online Journal)  
Impact Factor: 5.164



**Chief Editor**

**Dr. J.B. Helonde**

**Executive Editor**

**Mr. Somil Mayur Shah**

## ABSTRACT

In an electrical power system, the Line power to control high voltage to low voltage users. For operation of Line, its operational condition satellite communication use accurate monitored and maintained. Line power losses, the system working on time to time of the equipment on the Cumulative system. Since it is so expensive to repair or exchange a single Line, Implemented Line fault monitor and track location system in transmission line1,line2,line3.The Line fault tracking a monitor display has been implementation for phase in line power unit system.

A Tracking system has been design for Line fault monitor to Track location and detections in power electronics system and also we are using Microcontroller ATMEGA328 which indicate the Line monitor to detection of faults. Parameters like as voltage, current circuit and power energy use are done using protocol Communication USART Master Microcontroller is done. Units is found, wireless technology GSM & GPS Technology are used to send SMS to a monitor control unit section .

This satellite functions depend on GPS module as Line fault monitor detection when abnormality or emergency happens and wireless mobile communication technology. GSM modem is used exact mobile number to send message with coordinate track location using GPS to responsible person.

**KEYWORDS:** ATMEGA 328, Relay, Line fault detection, GPS technology , GSM technology ,Line line power transmission.

## 1. INTRODUCTION

This thesis presents the design and implementation of Line fault detection system based on GSM Modem and fault track location using GPS system. This system continuously monitors and records key parameters of distribution Line such as load voltage, load current and Line temperature. Continuous monitoring of the Line parameter has been achieved in the sub-stations through our system. Then we can take possible corrective action like balancing the loads on each phase or even switching the Line off can be taken before any failure happens. A prototype Line use in this system be used for line fault monitor.

This implemented design will help at utility to improve fault restoration time and we can utilize Lines for long period of time. Lines electric device are step-down power system components which are used at various voltage levels with the capacity varying from 1KVA to 600MVA. Any damage to this component results is completely loss in power system.

The communication system with mod bus protocol is implemented. Also use wireless technology GSM and GPS through which SMS send number to a message a control section on mobile. GSM and GPS modules have been for wireless communication applications.

The satellite include devices that recognize Antenna the existence of a Line monitor fault, indicates its location, detection some other abnormal fault like z-network analysis conditions and starts the inception steps of opening of circuit to disconnect the faulty equipment of the power electronics. The device development in the digital nand gate logic of power electronics and signal processing made it possible to microcontroller circuit board based relays work which provides a signal transmit GSM viable alternative to the fault circuit board. Advent of microcontroller digital algorithms successfully implemented design circuit for Line fault detection and track location.

**Faults In Line:-** In Electronics power unit system, a monitor to fault condition is any work to flow condition of electric current. As like a short condition circuit break is a Line fault in which current flow by passes through the normally load. if a circuit is interrupted by some failure. In R,Y,B line phase at the systems, a faulty may involving 1nd or other phase and that a ground, only 1 between phases. In a “ground fault” or “earth fault”, current pass into the ground. The proper short circuit fault at to current of a fault can be calculated for electronics power systems. In Line power electronics unit systems, protection devices monitor to detected a fault conditions and operate circuit trip a phase.

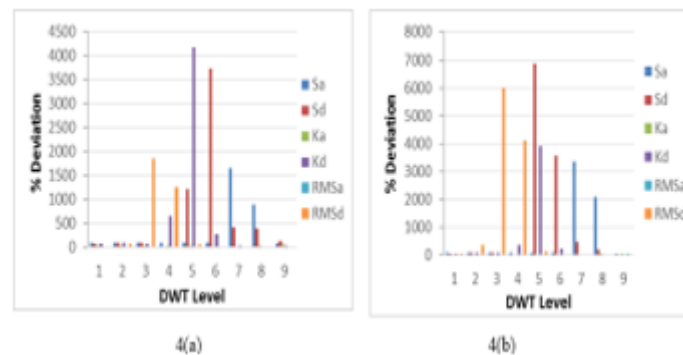

Figure.1:- Line fault parameter define

There are various faults in Line-

1. Line coil1 line fault ( change over phase fault, phase to ground fault)
2. Line coiling/winding fault.
3. Line fire.

#### 1. Line faults:-

- **Line1 to coil fault-** A short circuit between lines1line2, caused by Line of air or when lines come into physical contact. For i.e due Xmr to a broken insulator.
- **Line2 to GND fault-** A short circuit between Xmr line and ground (GND)very often caused by physical contact. For i.e due to coils lightning or other storm damage.
- **Double line3 to ground-** R,Y,B at the xmr phases at the lines come into contact with the ground coils (and each other), this also commonly due to storm damage



Figure.2:- line fault matlab simu link

#### 2. Line coiling fault :-

Line coiling fault comes under electrical internal fault. If primary coil winding insulation trip failure which often creates short circuit results in highly current flow. If the fault is at Xmr secondary copper coil winding due to side then a large current flow will result in secondary coil Xmr and it reflects high current

in coils Xmr coils at the primary winding. This high current provide at may break down the winding or even it may also damage the copper core fully. So far these faults the Line should be switched off immediately.

3. **Line Fire** :- The Line working at the temperature coolant system is high medium failure results in high temperature in Line which effects the Xmr oil insulation and heating casing. In long run this may result deterioration of component and may also create fire in the Line. This causes heating of Line and get fire.
4. **Mutual inductance**:- of a over voltage protection coil-1 and secondary coil-2 in response to a change in line1 current . Like to normally self- inductances, it is but un liked normally inductance it is showed by the capital letter "Pout" rather than the letter "Pin" The efficiency is then:

$$\eta = \frac{p_{out}}{p_{in}}$$

## 2. METHODOLOGY

The Lines fault detection to the system design and apply the method and detect the fault condition to if the Line and any fault to the line it is by-passed or by any mean the electricity is used the power d is monitor.

The Line fault detects the system in the condition of pursuing excellent accuracy. Because of the character of large scale development and passive data gathering, we propose using numerical taxonomy method to extract feature [10].Then algorithm is reset to detect new fault. In this way, it omits the to detect and transmit nodes' hardware parameters frequently, and does the calculating works in sink node which has unconstraint energy

We denote  $E$  as the initial signal of every node is showed by equations (1)(2).

$$\begin{cases} E_{Tx}(l, d) = lE_{elec} + l\varepsilon_{fs}d^2, if d \leq d_o & (1) \\ E_{Tx} = lE_{elec} + l\varepsilon_{amp}d^4, if d > d_o & (2) \end{cases}$$

$$E_{Rx}(l) = lE_{elec}$$

An inductor coil1-2 a circuit line fault monitor and detection located Xmr to oppose any phases the current through by it, Work must be as done to an a external source such ac change to dc power as a in order to establish a current in the inductor coil1 .Form the work-as apply KCL theorem, that incoming current in an inductor .The according to a role played Xmr by inductor coil2 in the generate flux in that magnetic field case is analogs to that of a

Line in the electric case.

$$PL = (dW_{ext})/dt = I_{ext}$$

The external emf and the inductor coil1 and cooil2 are present,

$$X_{mr} = -\varepsilon L \text{ which implies}$$

simulated to compare with FDNT, and we choose  $\alpha = 0.8$ ,

$\beta = 0.2$ ,  $\tau = 0.20$ . The simulation is showed in Figure 3 and the comparison is showed in

### Working and Principal

This implemented system design mainly for the Line Power system. The system design electricity will be Line coils1 and coils2 available for more number of turns in highly copper area. Firstly we give 230v AC power supply to the Line. Here we are using 12V,1Amp step down Line that convert 230v AC into 12v AC. From the output of the x-mer ,3 lines i.e. R,Y and B goes on rectifier circuit (Signal conditioning circuit). Each line having 2 wires ,one is phase and another is neutral. Diodes are connected in H pattern. Here we are using 1N4007 diode. It work as a rectifier that convert 12v AC into 12v DC. Capacitors are used in power supplies for smooth the output of a rectifier circuit. Here we are using three 7805 voltage regulator IC'S that fixed the voltage at 5volt. Register having 1k value and LED'S are

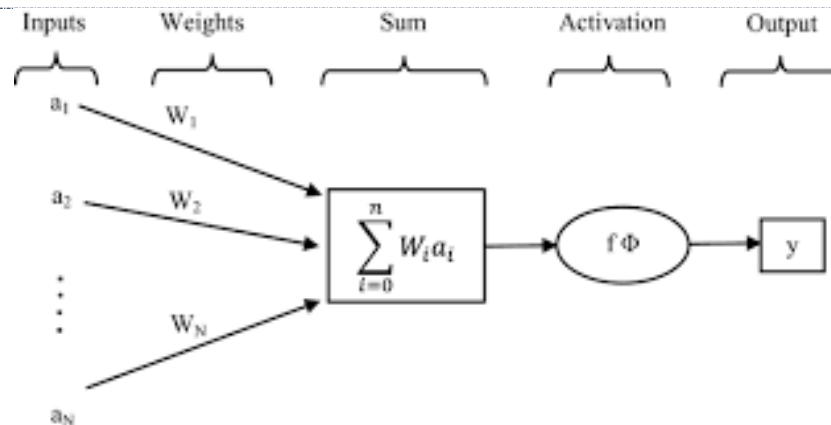

Figure.3:- Line fault equation to sum of current and voltage

also connected together in series for fault indication. Now 3 phase wires from this board goes to LCD board . Where these 3 wires are connected from three pin connector. This LCD board need an external power supply to operate this board ,so we connect 9v battery from it. Here we used 16x2 LCD DISPLAY and ATMEGA 328 microcontroller which is 28 pin . LCD and Microcontroller are interfaced together. Microcontroller's first pin is reset. It's second pin connect to GPS i.e. global positioning system and third pin is connected to GSM i.e. global system for mobile communication. Here we are using SIM28ML GPS Modem and SIM300 GSM Modem. Microcontroller's 4<sup>th</sup> pin connect to LCD's 4<sup>th</sup> pin i.e. register select. It's 5<sup>th</sup> pin connect to LCD's 6<sup>th</sup> pin i.e. enable. It's 7<sup>th</sup> pin connect to 5v supply. 8<sup>th</sup> pin of microcontroller connect to ground. 9<sup>th</sup> and 10<sup>th</sup> pin of microcontroller connect to crystal oscillator and ceramic capacitor. where crystal oscillator provides clock frequency and ceramic capacitor used for noise elimination. 11<sup>th</sup> ,12<sup>th</sup> and 13<sup>th</sup> pin of microcontroller connect to three phases i.e. R,Y & B. 14<sup>th</sup>,15<sup>th</sup>,16<sup>th</sup> & 17<sup>th</sup> pin of microcontroller connect to LCD's 14<sup>th</sup>,13,12<sup>th</sup> & 11<sup>th</sup> pin simultaneously these are data lines. 18<sup>th</sup> and 19<sup>th</sup> pin of microcontroller are open. 20<sup>th</sup> & 21<sup>st</sup> pin connect to VCC i.e.5v. 22<sup>nd</sup> pin goes to ground & 23<sup>rd</sup>-28<sup>th</sup> pin are open.

When system works properly LCD get initialized and display welcome message on it. If fault occurs in any one of the line , it indicates on LCD DISPLAY in the form of x-mer line1 fault, "X-mer" line2 fault or X-mer line3 fault with longitude and latitude. GPS trace the exact position of fault and GSM send the message to a responsible person. With the help of this monitoring ,tracking and messaging system we can recover the fault as soon as possible. It's save our time and prevent the possibility of big damage. If X-mer outer side having any trouble i.e. fire or smoke so fire sensor get activate. This fire sensor LM358 connect inside of the x-mer. It is also connect to LCD board with 2 pin connector. When x-mer starts the heating or any material fire outside of the x-mer this fire sensor get initialized and send the message on LCD in the form of x-mer heating. So we can protect the Line from fire. All this implemented system connects near about the distribution Line not in substation. Substation used only messaging purpose where the responsible person receives the message of fault and recover that fault as soon as possible. With the help of AT COMMANDS GSM send the message to one or more than one person it depends upon you how much number you add in it. All this system is connected to MPSEB also.



### 3. HARDWARE DESIGN

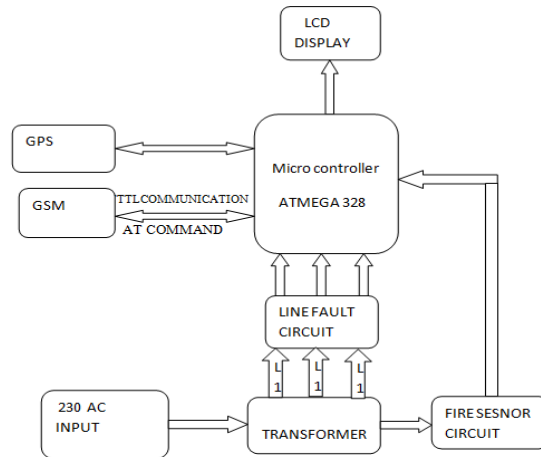

Figure.4:- Block diagram of line fault

#### Flow chart of fault detection

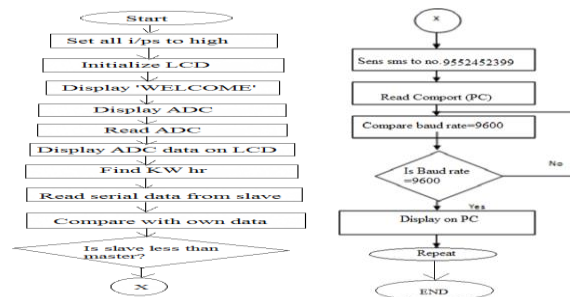

Figure.5:- Flowchart design line fault

### 4. CIRCUIT DESIGN

#### 4.1 Circuit monitor for fault matlab

This circuit for monitor to fault and send the fault Information

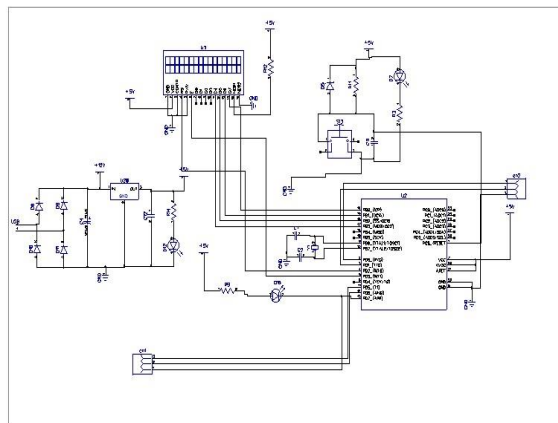

Figure.6:- Line fault monitor and tracking circuit

4.2 Circuit for fault

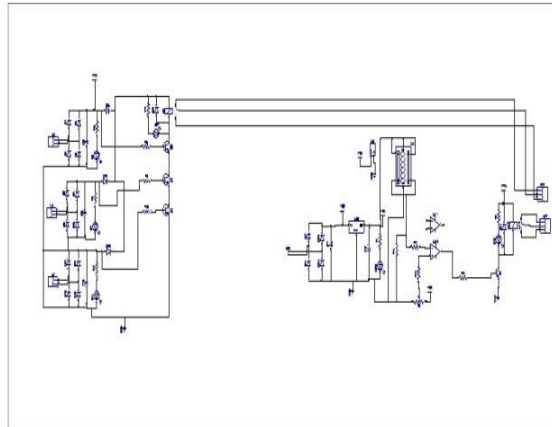

Figure.7:- 3 Phase Power Transmission Fault circuit

5. EXPERIMENTAL RESULTS

The experiment result of major parameters voltage and current are continuously fault monitor and detect the fault locate at the power control unit .R,Y,B Phase line 1,line2,line3 is done at by the master located the fault monitor coordinate at the control end. GSM modem is use to message to at the time of the fault of a and compulsory to use PC hyper terminal connect to modem set AT command .

Line fault monitor location and detection of faults condition is easy to take further corrective actions. If Line coil and lines faults not detected, then never to action against can be taken. So, keeping all these factors in mind, this is a challenging project. If this project becomes successful in implementation at least in any one part of the country, it will be a great achievement.

The Line has design a traditional design where setup down voltage the fire sensor is located in the electric field is while the Xmr coil's is locate on Xmr the inner side where the receive is set . The system to provide the 230volt AC output power 24 Volt AC. 3- wire is connected to the secondary coil of Xmr L1,L2,L3 this 3phase line the fault in the Line.

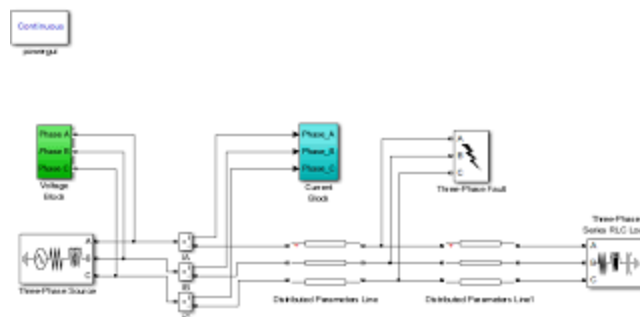

Figure.8:- Matlab based Line fault simulink

The all system design first PCB design by software, and Line design MATLAB BASED connected to a wire and coil turns 1000 and component soldering by PCB check the hardware of the system testing LCD display show the location and Fault and fault circuit Also design by PCB and connect to R, Y, B phase and GPS module also connect to this system and GSM modem connect to RX and TX pin Microcontroller USART communication.

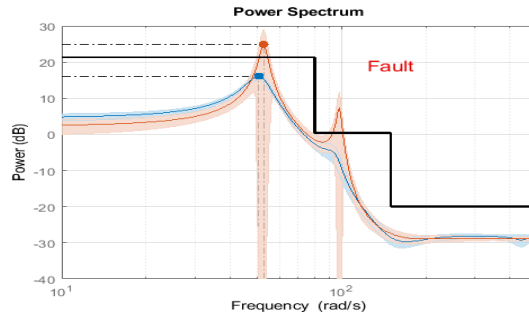

Figure.9:- Matlab based Line fault power spectrum present

Output voltage and current waveform

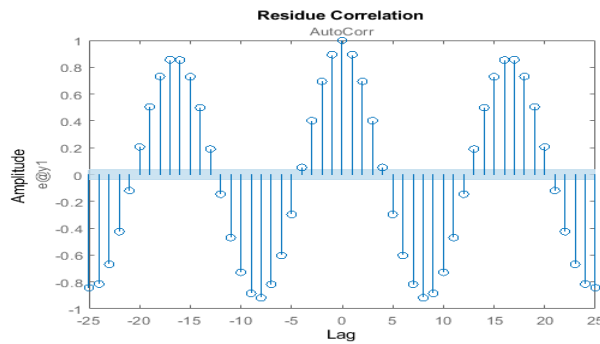

Figure 10.-: Output waves Form line fault

Result fault detection and location

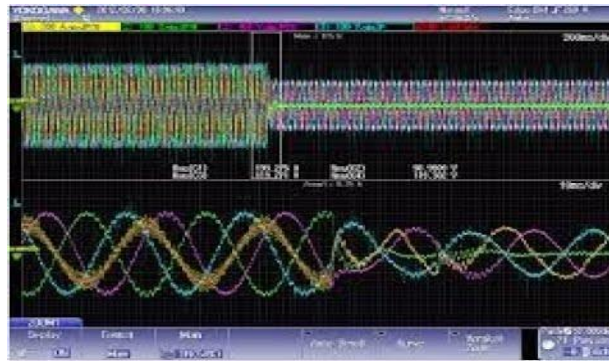

Figure 11.-: Line Fault detection MATLAB Simulink

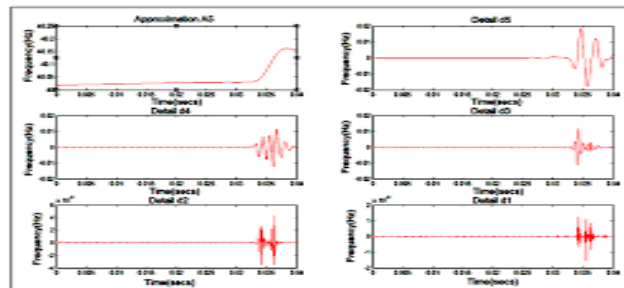

Figure.12 :- Impedance of Line fault



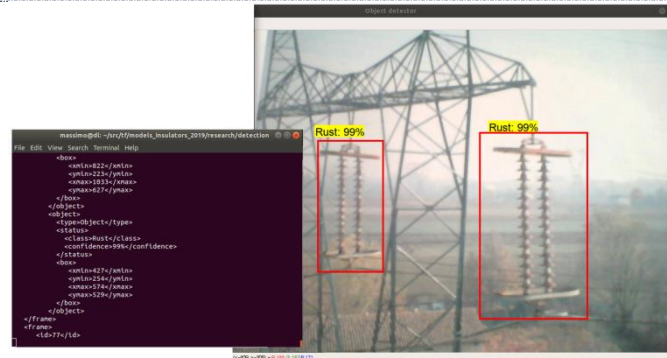

Figure.13:- Tracking location in Line fault

### Advantages of the system

- 1) This system design is very useful for electric power unit maintenance.
- 2) This System protection for very have loss for Line
- 3) In system can b control over load problem.
- 4) Power distribution unit to easy way for track fault location .
- 5) The system design very low cost .

### 6. CONCLUSION

The system design monitors various parameters fault of the Line line fault and monitor analyzing and fault detection location of a Line is done on the mobile. The modem via communication technology and the microcontroller instruction . In this thesis is working principle of the GSM and GPS modem. The system defines the hardware circuit flow chart and the software. The software design by module instruction different pathways of the electricity power unit section of electronics system. The implementation of the system of electricity and thereby electricity will be available for more number of consumers in a highly populated country such as India.

### Scope for feature work

A Line fault monitor at a module can be connect to this system for receiving and storing Line parameters information periodically about all the distribution power of Lines utility in a database application. This database will be a useful source of information on the utility Lines. The utility in monitoring the operational work of their distribution Lines and identify faults before at characteristics failures thus resulting in significant very cost saving fast working system reliability.

### REFERENCES

- [1] S. Jia, P. Yu and P. Xiyuan, "Fault Detection Technique based on Clustering in WSN", Chinese Journal of Scientific Instrument, (2012) October.
- [2] Aryadevi Remanidevi Devidas, Maneesha Vinodini Ramesh, "Wireless Smart grid design for monitoring and optimizing electric transmission in India" , IEEE 2010 Fourth International Conference on Technologies and Applications, Amrita Center for Wireless Networks & Applic., Amrita Vishwa Vidyapeetham (Amrita Univ.), Coimbatore, India, Dec 2010
- [3] Li Kong Huazhong Univ. of Sci.&Technol, Jing Jin ; Jingjing Cheng , "Introducing GPRS technology into remote monitoring system for prefabricated substations in China" , IEEE Journal on Mobil Technology, Applications and systems. DOI-15 Nov 2005.
- [4] CMS91-900/1800 GSM/GPRS Module-AT Commands Specification, Hardware specification: www.CELLon.com
- [5] Linear integrated circuits by National semiconductors (Analog circuits and Manuals), Oct 1999.
- [6] " Design monograph on Electrical circuit principles" by Goel and khetan, 7th edition Nov 1997.
- [7] "Electrical power supply system for India", www.wikipedia.org, February 2010
- [8] S.N.Singh, "Electric Power Generation, Transmission and Distribution", 2nded. Prentice-Hall of India Private Limited, 2000.
- [9] Jingjing Cheng, Jing Jin, Li Kong, Huazhong, "Wireless Distributed Monitoring and Centralized Controlling System for Prefabricated Substations in China", Univ. of Sci.&Technol., Hubei, China,



IEEE Journal, DOI-14 Dec 2005.

- [10] P. Yu, S. Jia and P. Xiyuan, "A Self Detection Technique in Fault Management in WSN", C. 2011 International instrumentation and measurement technology conference, (2013).
- [11] Abdul-Rahman AI-Ali, Abdul Khaliq & Muhammad Arshad," GSM-Based Distribution Line Monitoring System", IEEE MELECON 2004, May 12-15,2004, Vol 3 Pages-999-1002, Croatia.

